

(19) World Intellectual Property Organization
International Bureau



(43) International Publication Date
17 June 2004 (17.06.2004)

PCT

(10) International Publication Number
WO 2004/050221 A1

- (51) International Patent Classification⁷: B01D 65/08, 65/02
- (54) Agent: BALDWIN SHELSTON WATERS; 60 Margaret Street, Sydney, NSW 2000 (AU).
- (21) International Application Number: PCT/AU2003/001632
- (81) Designated States (national): AE, AG, AL, AM, AT, AU, AZ, BA, BB, BG, BR, BW, BY, BZ, CA, CH, CN, CO, CR, CU, CZ, DE, DK, DM, DZ, EC, EE, EG, ES, FI, GB, GD, GE, GH, GM, HR, HU, ID, IL, IN, IS, JP, KE, KG, KP, KR, KZ, LC, LK, LR, LS, LT, LU, LV, MA, MD, MG, MK, MN, MW, MX, MZ, NI, NO, NZ, OM, PG, PH, PL, PT, RO, RU, SC, SD, SE, SG, SK, SL, SY, TJ, TM, TN, TR, TT, TZ, UA, UG, US, UZ, VC, VN, YU, ZA, ZM, ZW.
- (22) International Filing Date: 5 December 2003 (05.12.2003)
- (25) Filing Language: English
- (26) Publication Language: English
- (30) Priority Data: 2002953111 5 December 2002 (05.12.2002) AU
- (84) Designated States (regional): ARIPO patent (BW, GH, GM, KE, LS, MW, MZ, SD, SL, SZ, TZ, UG, ZM, ZW), Eurasian patent (AM, AZ, BY, KG, KZ, MD, RU, TJ, TM), European patent (AT, BE, BG, CH, CY, CZ, DE, DK, EE, ES, FI, FR, GB, GR, HU, IE, IT, LU, MC, NL, PT, RO, SE, SI, SK, TR), OAPI patent (BF, BJ, CF, CG, CI, CM, GA, GN, GQ, GW, ML, MR, NE, SN, TD, TG).
- (71) Applicant (for all designated States except US): U.S. FILTER WASTEWATER GROUP, INC. [US/US]; 181 Thom Hill Road, Warrendale, PA 15086 (US).
- (72) Inventors; and
- (75) Inventors/Applicants (for US only): ZHA, Fufang [AU/AU]; 15A Grand Avenue, West Ryde, NSW 2114 (AU). PHELPS, Roger, William [AU/AU]; 32 Reading Avenue, Kings Langley, NSW 2147 (AU). BROIS, Etienne, Ulysse [FR/AU]; 2/30 Girraween Road, Girraween, NSW 2145 (AU).
- Declaration under Rule 4.17:
— of inventorship (Rule 4.17(iv)) for US only
- Published:
— with international search report

[Continued on next page]

(54) Title: MIXING CHAMBER

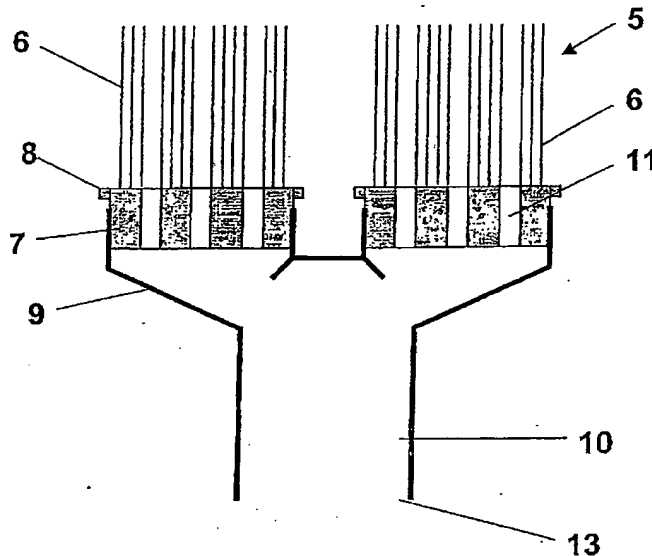

(57) Abstract: A membrane module (5) including a plurality of porous membranes (6) extending in an array and mounted, at least at one end, in a header (8). The header (8) has a number of distribution apertures (11) for distributing a fluid into the module (5) and along a surface or surfaces of the membranes (6). An elongate chamber (10) having one open end (13) and another end is in fluid communication with the distribution apertures (11) for distributing the fluid to the distribution apertures (11).

WO 2004/050221 A1



For two-letter codes and other abbreviations, refer to the "Guidance Notes on Codes and Abbreviations" appearing at the beginning of each regular issue of the PCT Gazette.

9/PRTS

10/537760
JC17 Rec'd PCT/PTO 06 JUN 2005

TITLE: MIXING CHAMBER

TECHNICAL FIELD

The present invention relates to apparatus and related methods for use of a chamber in association with membrane filtration modules to provide improved fluid distribution and flow into the associated modules.

BACKGROUND OF THE INVENTION

The importance of membranes for treatment of waste water is growing rapidly. It is now well known that membrane processes can be used as an effective tertiary treatment of sewage and provide quality effluent. However, the capital and operating cost can be prohibitive. With the arrival of submerged membrane processes where the membrane modules are immersed in a large feed tank and filtrate is collected through suction applied to the filtrate side of the membrane, membrane bioreactors combining biological and physical processes in one stage promise to be more compact, efficient and economic. Due to their versatility, the size of membrane bioreactors can range from household (such as septic tank systems) to the community and large-scale sewage treatment.

The success of a membrane filtration process largely depends on employing an effective and efficient membrane cleaning method. Commonly used physical cleaning methods include backwash (backpulse, backflush) using a liquid permeate or a gas, membrane surface scrubbing or scouring using a gas in the form of bubbles in a liquid. Examples of the second type of method is illustrated in United States Patent no 5,192,456 to Ishida et al, United States Patent No. 5,248,424 to Cote-et al, United States Patent No. 5,639,373 to Henshaw et al, United States Patent No. 5,783,083 to Henshaw et al and our PCT Application No. WO98/28066.

In the examples referred to above, a gas is injected, usually by means of a pressurised blower, into a liquid system where a membrane module is submerged to form gas bubbles. The bubbles so formed then travel upwards to scrub the membrane surface to remove the fouling substances formed on the membrane surface. The shear force produced largely relies on the initial gas bubble velocity, bubble size and the resultant of forces applied to the bubbles. The fluid transfer in this approach is limited to the effectiveness of the gas lifting mechanism. To enhance the scrubbing effect, more gas has to be supplied. However, this method has several disadvantages: it consumes large amounts of energy, possibly forms mist or froth flow reducing effective membrane filtration area, and may be destructive to membranes. Moreover, in an environment of high concentration of solids, the gas distribution system may gradually become blocked by dehydrated solids or simply be blocked when the gas flow accidentally ceases.

For most capillary membrane modules, the membranes are flexible in the middle (longitudinal direction) of the modules but tend to be tighter and less flexible towards to both potted heads. When such modules are used in an environment containing high concentrations of suspended solids, solids are easily trapped within the membrane bundle, especially in the proximity of two potted heads. The methods to reduce the accumulation of solids include the improvement of module configurations and flow distribution when gas scrubbing is used to clean the membranes.

Our earlier International Application No. WO 00/18498 describes the use of a mixture of gas and liquid to effectively clean the surface of membranes. The arrangements and methods described herein provided another simple way of achieving effective scouring of membrane surfaces.

DISCLOSURE OF THE INVENTION

The present invention, at least in its embodiments, seeks to overcome or least

ameliorate some of the disadvantages of the prior art or at least provide the public with a useful alternative.

According to one aspect the present invention provides a membrane module including a plurality of porous membranes extending in an array and mounted, at least at
5 one end, in a header, said header having a number of distribution apertures for distributing a fluid into said module and along a surface or surfaces of said membranes, a chamber having one open end and another end in fluid communication with said
15 distribution apertures for distributing said fluid to said distribution apertures.

In an alternative aspect, the present invention provides an assembly of membrane
10 modules including a plurality of porous membranes extending in an array and mounted, at least at one end, in a plurality of respective headers, said headers being configured to provide a number of distribution apertures therebetween for distributing a fluid into said
assembly of membrane modules and along a surface or surfaces of said membranes, a chamber having one open end and another end in fluid communication with said
15 distribution apertures for distributing said fluid to said distribution apertures.

In one form of the invention, the fluid may be gas, usually air and in another form of the invention the fluid may be a mixture of gas and liquid, usually air and feed liquid.

The term liquid as used herein will be familiar to those skilled in the art as encompassing the range of other materials usually considered as liquid feeds, such as
20 suspensions which contain suspended solids or inorganic matter in liquids, suspensions of biomass in water, water which is turbid and the like, or mixtures of these.

Preferably, the chamber is elongate, that is, preferably, the length of said chamber is greater than that required to provide a static head, when the membrane is immersed in a liquid and gas introduced into the chamber, equivalent to the head loss for the gas to flow
25 to said distribution apertures. That is, the length of the chamber should be sufficient that

all gas flows from the supply source or manifold through the distribution apertures rather than the open end of the chamber.

While the term mixing chamber is used, it would also be possible to describe the present invention as a mixing junction.

5 In some embodiments, the chamber is enclosed on all sides. However, if the chamber is sufficiently dimensioned, it may not be necessary for the sides to be enclosed. By way of example only, if the membrane module or an array of modules is in the form of a linear array, with a plurality of headers, then it may be sufficient just for the chamber to be enclosed along the two longest sides. Preferably, the membrane module is in the
10 form of an extended linear array wherein the chamber has enclosed long sides. More preferably, the membrane module is in the form of an extended linear array wherein the chamber has unenclosed short sides.

In yet a further alternative, the chamber may have sides but no top. In such a case, the sides of the chamber are positioned to substantially form a skirt below the
15 header or group of headers. In such a case, the sides of the chamber may not be parallel, but, for example, may slope inwardly towards the header.

The chamber can be of any shape as desired to contain any configuration of membrane modules. In preferred embodiments, the header or headers are mounted in a clover shaped manifold. The clover manifold is so called because when viewed from
20 above, the manifold has the shape of a clover leaf. While the invention is described with reference to this one preferred embodiment, it will be understood that the manifold can be configured to have any desired footprint, for example, it may be linear, rectangular, square, hexagonal etc.

According to another aspect, the present invention provides a method of removing
25 a fouling material from a plurality of porous hollow fiber membranes mounted and

extending longitudinally in an array to form a membrane module, the method comprising the steps of:

providing a source of gas to a chamber in fluid communication with said membrane module;

- 5 flowing the gas from the chamber into a base of the membrane module to form gas bubbles therein when said module is immersed in a liquid, whereby an upward flow of the gas bubbles across surfaces of the hollow fiber membranes is obtained, and whereby fouling materials are dislodged from the surfaces of the porous hollow fiber membranes.

The source of gas can be provided to the chamber either within the chamber itself,
10 or from below the chamber.

Preferably, said chamber is elongate with one end open and the other end in fluid communication with the membrane module. For preference, the gas is provided through the open end of the chamber.

According to another aspect, the present invention provides a method of removing
15 a fouling material from a plurality of porous hollow fiber membranes mounted and extending longitudinally in an array to form a membrane module, the method comprising the steps of:

forming a mixture of gas bubbles and liquid within a mixing chamber;

injecting the mixture into a base of the membrane module, whereby an upward flow of
20 the mixture across surfaces of the hollow fiber membranes is obtained, and whereby fouling materials are dislodged from the surfaces of the porous hollow fiber membranes.

For preference, the step of forming a mixture includes entraining the gas bubbles into a liquid stream. Preferably, the gas bubbles are entrained into said liquid stream by means of the chamber. For further preference, the gas bubbles are entrained or injected
25 into said liquid stream by means of devices which forcibly mix gas into a liquid flow to

produce a mixture of liquid and bubbles, such devices including a jet, nozzle, ejector, eductor, injector or the like. The gas used may include air, oxygen, gaseous chlorine or ozone. Air is the most economical for the purposes of scrubbing and/or aeration.

Gaseous chlorine may be used for scrubbing, disinfection and enhancing the cleaning efficiency by chemical reaction at the membrane surface. The use of ozone, besides the similar effects mentioned for gaseous chlorine, has additional features, such as oxidising DBP (disinfection by-product) precursors and converting non-biodegradable NOM's (natural organic matters) to biodegradable dissolved organic carbon.

It is generally preferred if the air entering the mixing chamber is deflected away from the source of the liquid which is entering the mixing chamber. Preferably, the air entering the mixing chamber is deflected, for example, by way of a T-piece or baffle. The liquid preferably enters the mixing chamber by way of a nozzle.

According to a further aspect, the present invention provides a membrane module comprising a plurality of porous membranes, said membranes being arranged in close proximity to one another, a mixing chamber in fluid communication with said module for mixing together liquid and gas bubbles to provide a cleaning mixture and means for flowing said cleaning mixture along the surface of said membranes to dislodge fouling materials therefrom.

According to one preferred form, the present invention provides a method of removing fouling materials from the surface of a plurality of porous hollow fibre membranes mounted and extending longitudinally in an array to form a membrane module, said membranes being arranged in close proximity to one another, the method comprising the steps of forming a mixture of gas bubbles and liquid within a mixing chamber, said mixture being formed by said gas bubbles being entrained in said liquid by flowing said liquid past a source of gas so as to cause said gas to be drawn and/or mixed

into said liquid, flowing said mixture into said membrane module such that said bubbles pass substantially uniformly between each membrane in said array to, in combination with said liquid flow, scour the surface of said membranes and remove accumulated solids from within the membrane module.

5 For preference, the membranes comprise porous hollow fibres, the fibres being fixed at each end in a header, the lower header having one or more holes formed therein through which mixture of gas/liquid is introduced from the mixing chamber. The holes can be circular, elliptical or in the form of a slot.

Preferably, the membranes comprise porous hollow fibres, the fibres being fixed at
10 each end in a plurality of headers, the lower headers being configured to provide a number of distribution apertures therebetween through which mixture of gas/liquid is introduced from the mixing chamber.

The fibres are normally sealed at the lower end and open at their upper end to allow removal of filtrate, however, in some arrangements, the fibres may be open at both ends
15 to allow removal of filtrate from one or both ends. It will be appreciated that the cleaning process described is equally applicable to other forms of membrane such flat or plate membranes.

Alternatively, the membranes may be flat sheet or curtain like hollow fibre modules, with apertures in the header configured parallel to the flat sheet.

20 In yet a further alternative embodiment, a plurality of headers without apertures may be used, provided these are spaced such that the gaps between the headers define an aperture or apertures for the fluid and gas bubbles to scrub the membranes.

In an example of this alternative aspect, the membrane module includes a plurality of porous membranes extending in an array and potted in headers. Said modules are
25 mounted in such a way that said headers are configured to provide a number of

distribution apertures therebetween for distributing a fluid into said modules and along surfaces of said membranes, a chamber having one open end and another end in fluid communication with said distribution apertures for distributing said fluid to said distribution apertures.

5 Particularly in the case of flat-sheet membranes or curtain-like hollow fiber modules, where there are no apertures in the lower header, apertures or passages for fluid and gas bubbles can be formed by mounting modules in close proximity leaving a gap or gaps between modules.

A mixing chamber can enclose several modules in an array.

10 According to yet a further aspect, the present invention provides a membrane module for use in a membrane bioreactor including a plurality of porous hollow membrane fibres extending longitudinally between and mounted at each end to a respective potting head, said membrane fibres being arranged in close proximity to one another, said fibres being partitioned into a number of bundles at least at or adjacent to
15 their respective potting head so as to form a space therebetween, a mixing chamber connected or open to a source of gas and liquid, one of said potting heads having an array of openings formed therein in fluid communication with said chamber for providing gas bubbles within said module such that, in use, said bubbles move past the surfaces of said membrane fibres to dislodge fouling materials therefrom.

20 According to a further aspect, the invention provides a membrane module for use in a membrane bioreactor including a plurality of porous hollow membrane fibres extending longitudinally between and mounted at each end to a plurality of respective potting heads, said membrane fibres being arranged in close proximity to one another, said fibres being partitioned into a number of bundles at least at or adjacent to their respective potting head
25 so as to form a space therebetween, a mixing chamber connected or open to a source of

gas and liquid, said potting heads being configured to provide a number of distribution apertures therebetween in fluid communication with said chamber for providing gas bubbles within said module such that, in use, said bubbles move past the surfaces of said membrane fibres to dislodge fouling materials therefrom.

5 The liquid used may be the feed to the membrane module. The fibres and/or fibre bundles may cross over one another between the potting heads though it is desirable that they do not.

Preferably, the fibres within the module have a packing density (as defined above) of between about 5 to about 70% and, more preferably, between about 8 to about 55%.

10 For preference, said holes have a diameter in the range of about 1 to 40 mm and more preferably in the range of about 1.5 to about 25 mm. In the case of a slot or row of holes, the width of slots are chosen to be equivalent to the diameter of the above holes..

Typically, the fibre inner diameter ranges from about 0.1 mm to about 5 mm and is preferably in the range of about 0.25 mm to about 2 mm. The fibres wall thickness is
15 dependent on materials used and strength required versus filtration efficiency. Typically wall thickness is between 0.05 to 2 mm and more often between 0.1 mm to 1 mm.

For preference, the membrane modules of the present invention include a deflector within said mixing chamber configured to deflect gas away from the source of the liquid. It is also preferred if the membrane modules of the present invention include a nozzle
20 whereby liquid is introduced into the mixing chamber.

According to another aspect, the present invention provides a membrane bioreactor including a tank having means for the introduction of feed thereto, means for forming activated sludge within said tank, a membrane module according to other aspects of the present invention positioned within said tank so as to be immersed in said sludge and said
25 membrane module provided with means for withdrawing filtrate from at least one end of

said fibre membranes.

According to yet another aspect, the present invention provides a method of operating a membrane bioreactor of the type described in the above aspect comprising introducing feed to said tank, applying a vacuum to said fibres to withdraw filtrate
5 therefrom while periodically or continuously supplying a cleaning mixture of gas bubbles and liquid formed in a mixing chamber through said openings to within said module such that, in use, said cleaning mixtures flows along the surface of said membrane fibres to dislodge fouling materials therefrom.

If required, a further source of aeration may be provided within the tank to assist
10 microorganism activity and to reduce anoxic zone. For preference, the membrane module is suspended vertically within the tank and said further source of aeration may be provided beneath the suspended module. Preferably, the further source of aeration comprises a group of air permeable tubes or discs. The membrane module may be operated with or without backwash depending on the flux. A high mixed liquor of
15 suspended solids (5,000 to 20,000 ppm) in the bioreactor has been shown to significantly reduce residence time and improve filtrate quality. The combined use of aeration for both degradation of organic substances and membrane cleaning has been shown to enable constant filtrate flow without significant increases in transmembrane pressure while establishing high concentration of MLSS. The use of partitioned fibre bundles enables
20 higher packing densities to be achieved without significantly compromising the gas scouring process. This provides for higher filtration efficiencies to be gained.

BRIEF DESCRIPTION OF THE DRAWINGS

Preferred embodiments of the invention will now be described, by way of example only, with reference to the accompanying drawings in which:-

Figure 1 shows a pictorial side elevation of a chamber and membrane modules according to an embodiment of the invention;

Figure 2 shows a pictorial side elevation of a chamber and membrane modules according to a second embodiment of the invention;

5 Figure 3 shows a pictorial side elevation of a chamber and membrane modules according to a third embodiment of the invention;

Figure 4 shows a pictorial side elevation of a chamber and membrane modules according to a fourth embodiment of the invention;

Figure 5 shows a pictorial side elevation of a chamber and membrane modules
10 according to a fifth embodiment of the invention; and

Figure 6 shows a schematic side elevation of a chamber and membrane module according to a sixth embodiment of the invention.

Figure 7 shows a pictorial side elevation of a chamber and membrane modules according to another embodiment of the invention.

15 Figure 8a shows a preferred embodiment of the deflector for use in mixing chambers of the present invention.

Figure 8b shows a further referred embodiment of the deflector for use in mixing chambers of the present invention.

Figure 9 shows a preferred embodiment of an extended chamber and linear array of
20 modules

PREFERRED EMBODIMENTS OF THE INVENTION

Referring to the drawings, the embodiments of the invention will be described in relation to a membrane module of the type disclosed in our earlier PCT application Nos. 5 WO98/28066 and WO00/18498 which are incorporated herein by cross-reference, however, it will be appreciated that the invention is equally applicable to other forms of membrane module.

As shown in Figure 1, the membrane module 5 typically comprises fibre, tubular or flat sheet form membranes 6 potted into a pot 7 which is supported by a header 8. The 10 membranes are typically encased in a support structure (not shown). In the embodiment shown, the headers 8 are coupled to a clover type manifold 9 which in turn is connected to an open ended elongate chamber 10 positioned below the manifold 9. The membrane module is typically immersed in a feed tank and either one or both ends of the membranes may be used for the permeate collection. The bottom of each membrane 15 module 5 has a number of through apertures 11 in the pot 7 to distribute gas or a mixture of gas and liquid feed past the membrane surfaces.

Figure 2 shows an embodiment where the chamber 10 is used to produce a liquid/gas bubble mixture by providing a source of gas 12 within the chamber 10 and flowing feed liquid through the chamber 10 to mix with a gas flow or gas bubbles 20 produced from the gas source 12. In this embodiment the gas is fed from above through the clover manifold 9 as the membrane modules are typically suspended vertically in a feed tank, however, it will be appreciated that the gas may be provided to the chamber by any desired arrangement. The chamber 10 is open at its base 13 and liquid is flowed from a pipe 14 upwardly through the chamber 10 to mix with gas provided from a source 25 12 within the chamber 10. If necessary, a non-return valve (not shown) or the like may

be attached to the gas source 12 to prevent the liquid phase entering the gas manifold.

The two fluids are mixed within the chamber 10 before being fed and uniformly distributed into the membrane modules 5 via the distribution apertures 11. The chamber 10 may be directly connected to a gas source 12 and/or liquid or as a capture and mixing
5 device.

Referring to Figure 3, the chamber is shown in its application as a device to capture gas and/or liquid flow injected beneath it at its base 13. The fluid flow energy is therefore concentrated in the chamber 10 before distribution into the membrane modules
5. In this arrangement the chamber 10 is again open-ended at its base 13 but gas or liquid
10 is provided from a source, in this case a pipe 14, below the open end and the chamber is used to capture the upward flow of these fluids for communication to the distribution apertures 11.

A similar embodiment is shown in Figure 4. In this embodiment, a venturi device 15 or the like is positioned at the base 13 of the chamber 10. The venturi device 15
15 intakes gas through inlet 16, mixes or entrains the gas with liquid flowing through feed inlet 17, forms gas bubbles and diffuses the liquid/gas mix into the chamber 10. The liquid/gas mixture passes upwardly from the chamber 10 into the lower header 8 and through the distribution apertures 11. Liquid feed is also drawn through the open end of the chamber 10 by liquid/gas flow from the venturi device 15. The entrained gas bubbles
20 scrub membrane surfaces while travelling upwards along with the liquid flow. Either the liquid feed or the gas can be a continuous or intermittent injection depending on the system requirements. With a venturi device it is possible to create gas bubbles and aerate the system without a blower. The venturi device 15 can be a venturi tube, jet, nozzle, ejector, eductor, injector or the like.

25 Although the embodiments of Figures 3 and 4 are shown with an open-ended

chamber 10, it will be appreciated that a closed chamber may be used with gas and liquid being directly injected into the chamber.

The liquid commonly used to entrain the gas is the feed water, wastewater or mixed liquor to be filtered. Pumping such an operating liquid through a venturi or the
5 like creates a vacuum to suck the gas into the liquid, or reduces the gas discharge pressure when a blower is used. By providing the gas in a flow of the liquid, the possibility of blockage of the distribution apertures 11 is substantially reduced.

The arrangement shown in the embodiment of Figure 5 also serves to reduce the likelihood of blockage of the distribution apertures 11 by large particles. In this
10 arrangement gas, typically air, is injected into the clover manifold 9 and the chamber 10 is lengthwise dimensioned to be greater than that required to provide a static head, when the membrane is immersed in a liquid and gas introduced into the chamber 10, equivalent to the head loss for the gas to flow to said distribution apertures 11. As can be seen from the figure, as gas enters from above it forces the liquid within the chamber 10 downwards
15 until the gas flowing through the distribution apertures 11 equalizes the pressure within the chamber 10 and forms a liquid seal 18 to prevent gas passing outward through the lower open end 13 of the chamber 10. Such an arrangement has been found to prevent large particles within the feed liquid flowing into and blocking the distribution apertures 11. These large particles usually remain within the chamber 10 and settle under gravity
20 following which they can be removed during the usual drain down of the feed tank.

Figure 6 shows a similar arrangement to Figure 3 but with a single membrane module 5. Chamber 10 again captures gas or liquid/gas flow from source 12 and distributes the flow to apertures 11 in pot 7. The flow then passes upwardly between the membranes 6. In the embodiment shown filtrate is withdrawn from the upper header 19
25 and a screen 20 is provided between the headers to support the membranes 6.

Figure 7 shows a further embodiment of the invention in which gas or liquid/gas flow from source 12 is deflected within chamber 10 by means of a deflector 30. The deflector may be, for instance, a T-piece or more particularly a baffle. The deflector preferably functions to prevent the flow 12 from interfering with the flow of air or liquid from source 14. In the particular embodiment shown, the liquid flow into the chamber from 14 is via a nozzle 15. The deflector is shown attached to, and positioned adjacent to, air source 12, however, it could be attached to, and positioned adjacent to nozzle 15. Alternatively, it could be not directly attached to either air or gas source, but disposed intermediate the two.

10 The use of a nozzle is generally preferred over the use of a sparger. The nozzle is any device which gradually reduces the cross sectional area of the throat through which the gas or liquid passes. Nozzles have been found particularly advantageous because they can achieve high fluid velocities with relatively low energy losses. This in turn results in better mixing.

15 Figure 8 shows one particular form of deflector according to the present invention.

Figure 9 shows a particular embodiment of the invention which is suitable for scrubbing a linear array of modules. A plurality of arrays are connected to a mixing chamber 10 of extended length. The gas manifold 12 is disposed below the mixing chamber, and the liquid source 14 is disposed below the gas manifold. A nozzle 15 is preferably used. The liquid and gas are mixed in or below the chamber and exit via apertures 11, scrubbing fibres 6 as they move upwards.

It will be appreciated that further embodiments and exemplifications of the invention are possible without departing from the spirit or scope of the invention described.

CLAIMS:

1. A membrane module including a plurality of porous membranes extending in an array and mounted, at least at one end, in a header, said header having a number of
5 distribution apertures for distributing a fluid into said module and along a surface or surfaces of said membranes, a chamber having one open end and another end in fluid communication with said distribution apertures for distributing said fluid to said
distribution apertures.
2. A membrane module according to claim 1 wherein the chamber is elongate
- 10 3. A membrane module according to claims 1 or claim 2 wherein the length of said chamber is greater than that required to provide a static head, when the membrane is immersed in a liquid and gas introduced into the chamber, equivalent to the head loss for the gas to flow to said distribution apertures.
4. A membrane module according to any one of the preceding claims wherein the
15 fluid is gas.
5. A membrane module according to any one of claims 1 to 3 wherein the fluid is a mixture of gas and liquid.
6. A membrane module any one of the preceding claims wherein the chamber is enclosed on all sides.
- 20 7. A membrane module according to any one of preceding claims wherein the header or headers are mounted in a clover shaped manifold.
8. A membrane module according to any one of claims 1 to 6 wherein the header or headers are mounted in a linear, rectangular, square, or hexagonal manifold.

9. A membrane module according to any one of the preceding claims wherein the chamber has a plurality of sides positioned to form a skirt directly beneath a header or plurality of headers.
10. An array of membrane modules according to any one of the preceding claims when
5 arranged in the form of an extended linear array wherein the chamber has enclosed long sides.
11. An array of membrane modules according to claim 10 in the form of an extended linear array wherein the chamber has unenclosed short sides.
12. An assembly of membrane modules including a plurality of porous membranes
10 extending in an array and mounted, at least at one end, in a plurality of respective headers, said headers being configured to provide a number of distribution apertures therebetween for distributing a fluid into said assembly of membrane modules and along a surface or surfaces of said membranes, a chamber having one open end and another end in fluid communication with said distribution apertures for distributing said fluid to said
15 distribution apertures.
13. An assembly of membrane modules according to claim 12 wherein the chamber is elongate.
14. An assembly of membrane modules according to claim 12 or claim 13 wherein the
20 length of said chamber is greater than that required to provide a static head, when the membrane is immersed in a liquid and gas introduced into the chamber, equivalent to the head loss for the gas to flow to said distribution apertures.
15. An assembly of membrane modules according to any one of claims 12 to 14 wherein the fluid is gas.
16. An assembly of membrane modules according to any one of claims 12 to 15
25 wherein the fluid is a mixture of gas and liquid.

17. An assembly of membrane modules any one of claims 12 to 16 wherein the chamber is enclosed on all sides.
18. An assembly of membrane modules according to any one of claims 12 to 17 wherein the header or headers are mounted in a clover shaped manifold.
- 5 19. An assembly of membrane modules according to any one of claims 12 to 17 wherein the header or headers are mounted in a linear, rectangular, square, or hexagonal manifold.
20. An assembly of membrane modules according to any one of claims 12 to 19 wherein the chamber has a plurality of sides positioned to form a skirt directly beneath a
10 header or plurality of headers
21. An assembly of membrane modules according to any one of claims 12 to 20 when arranged in the form of an extended linear array wherein the chamber has enclosed long sides.
22. An assembly of membrane modules according to any one of claims 12 to 21 in the
15 form of an extended linear array wherein the chamber has unenclosed short sides.
23. A method of removing a fouling material from a plurality of porous hollow fiber membranes mounted and extending longitudinally in an array to form a membrane module, the method comprising the steps of:
providing a source of gas to a chamber in fluid communication with said membrane
20 module;
flowing the gas from the chamber into a base of the membrane module to form gas bubbles therein when said module is immersed in a liquid, whereby an upward flow of the gas bubbles across surfaces of the hollow fiber membranes is obtained, and whereby fouling materials are dislodged from the surfaces of the porous hollow fiber membranes.

24. A method according to claim 23 wherein the source of gas to the chamber is provided within the chamber.
25. A method according to claim 23 wherein the source of gas to the chamber is provided from below the chamber.
- 5 26. A method according to claim 23 wherein said chamber is elongate with one end open and the other end in fluid communication with the membrane module.
27. A method according to claim 26 wherein the gas is provided through the open end of the chamber.
28. A method of removing a fouling material from a plurality of porous hollow fiber
10 membranes mounted and extending longitudinally in an array to form a membrane module, the method comprising the steps of:
forming a mixture of gas bubbles and liquid within a mixing chamber;
injecting the mixture into a base of the membrane module, whereby an upward flow of the mixture across surfaces of the hollow fiber membranes is obtained, and whereby fouling
15 materials are dislodged from the surfaces of the porous hollow fiber membranes.
29. A method according to claim 28 wherein the step of forming a mixture includes entraining the gas bubbles into a liquid stream.
- 30 A method according to claim 29 wherein the gas bubbles are entrained into said liquid stream by means of the chamber.
- 20 31. A method according to claim 29 wherein the gas bubbles are entrained or injected into said liquid stream by means of devices which forcibly mix gas into a liquid flow to produce a mixture of liquid and bubbles.
32. A method according to any one of claims 23 to 31 wherein air entering the mixing chamber is deflected.
- 25 33. A method according to claim 32 wherein air entering the mixing chamber is deflected

by way of a T-piece or baffle.

34. A method according to claim 32 or 33 wherein air entering the mixing chamber is deflected away from liquid entering the mixing chamber by way of a nozzle.

35. A membrane module comprising a plurality of porous membranes, said membranes
5 being arranged in close proximity to one another, a mixing chamber in fluid communication with said module for mixing together liquid and gas bubbles to provide a cleaning mixture and means for flowing said cleaning mixture along the surface of said membranes to dislodge fouling materials therefrom.

36. A method of removing fouling materials from the surface of a plurality of porous
10 hollow fibre membranes mounted and extending longitudinally in an array to form a membrane module, said membranes being arranged in close proximity to one another, the method comprising the steps of forming a mixture of gas bubbles and liquid within a mixing chamber, said mixture being formed by said gas bubbles being entrained in said liquid by flowing said liquid past a source of gas so as to cause said gas to be drawn and/or
15 mixed into said liquid, flowing said mixture into said membrane module such that said bubbles pass substantially uniformly between each membrane in said array to, in combination with said liquid flow, scour the surface of said membranes and remove accumulated solids from within the membrane module.

37. A method according to claim 36 wherein the membranes comprise porous hollow
20 fibres, the fibres being fixed at each end in a header, the lower header having one or more holes formed therein through which mixture of gas/liquid is introduced from the mixing chamber.

38. A method according to claim 37 wherein the holes are circular, elliptical or in the form of a slot.

25 39. A method according to claim 36 wherein the membranes comprise porous hollow

fibres, the fibres being fixed at each end in a plurality of headers, the lower headers being configured to provide a number of distribution apertures therebetween through which mixture of gas/liquid is introduced from the mixing chamber.

40. A membrane module for use in a membrane bioreactor including a plurality of porous hollow membrane fibres extending longitudinally between and mounted at each end to a respective potting head, said membrane fibres being arranged in close proximity to one another, said fibres being partitioned into a number of bundles at least at or adjacent to their respective potting head so as to form a space therebetween, a mixing chamber connected or open to a source of gas and liquid, one of said potting heads having an array of openings formed therein in fluid communication with said chamber for providing gas bubbles within said module such that, in use, said bubbles move past the surfaces of said membrane fibres to dislodge fouling materials therefrom.

41. An assembly of membrane modules for use in a membrane bioreactor including a plurality of porous hollow membrane fibres extending longitudinally between and mounted at each end to a plurality of respective potting heads, said membrane fibres being arranged in close proximity to one another, said fibres being partitioned into a number of bundles at least at or adjacent to their respective potting head so as to form a space therebetween, a mixing chamber connected or open to a source of gas and liquid, said potting heads being configured to provide a number of distribution apertures therebetween in fluid communication with said chamber for providing gas bubbles within said assembly of membrane modules such that, in use, said bubbles move past the surfaces of said membrane fibres to dislodge fouling materials therefrom.

42. A membrane module or assembly according to claim 40 or claim 41 wherein the liquid used is feed to the membrane module.

43. A membrane module or assembly according to any one of claims 40 to 42 wherein

the fibres within the module have a packing density of between about 5 to about 70%.

44 A membrane module or assembly according to claim 43 wherein the packing density is between about 8 to about 55%.

45. A membrane module or assembly according to any one of claims 40 to 44 wherein
5 said holes have a diameter in the range of about 1 to 40 mm.

46. A membrane module or assembly according to claim 45 wherein said holes have a diameter in the range of about 1.5 to about 25 mm.

47. A membrane module or assembly according to any one of claims 40 to 46 including a
deflector within said mixing chamber configured to deflect gas away from the source of the
10 liquid.

48. A membrane module or an assembly according to any one of claims 1 to 9, 12 to 22,
35, or 40 to 47 including a nozzle whereby liquid is introduced into the mixing chamber.

49. A membrane bioreactor including a tank having means for the introduction of feed
thereto, means for forming activated sludge within said tank, a membrane module or an
15 assembly according to any one of claims 1 to 9, 12 to 22, 35, or 40 to 48 positioned within
said tank so as to be immersed in said sludge and said membrane module provided with
means for withdrawing filtrate from at least one end of said fibre membranes.

50. A method of operating a membrane bioreactor of the type according to claim 49,
comprising introducing feed to said tank, applying a vacuum to said fibres to withdraw
20 filtrate therefrom while periodically or continuously supplying a cleaning mixture of gas
bubbles and liquid formed in a mixing chamber through said openings to within said
module such that, in use, said cleaning mixtures flows along the surface of said membrane
fibres to dislodge fouling materials therefrom.

51. A membrane bioreactor according to claim 49 wherein a further source of aeration
25 is provided within the tank to assist microorganism activity.

52. A membrane bioreactor according to claim 51 wherein the membrane module is suspended vertically within the tank and said further source of aeration is provided beneath the suspended module.

53. A membrane bioreactor according to claim 52 wherein the further source of
5 aeration comprises a group of air permeable tubes.

10/537760

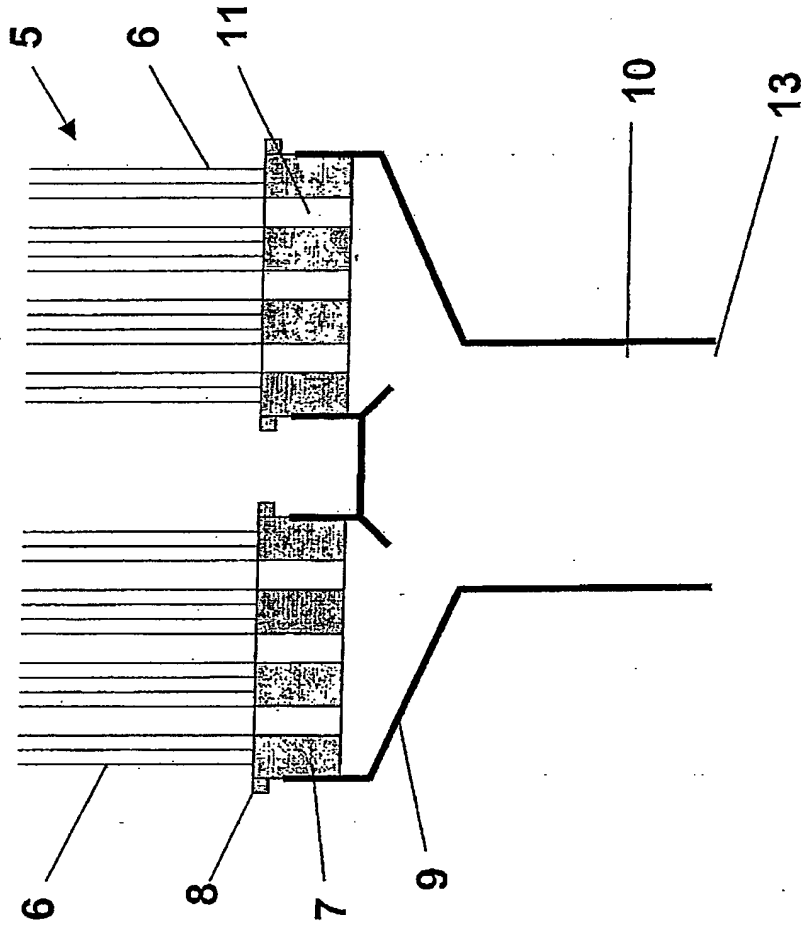

Figure 1.

10/537760

2/9

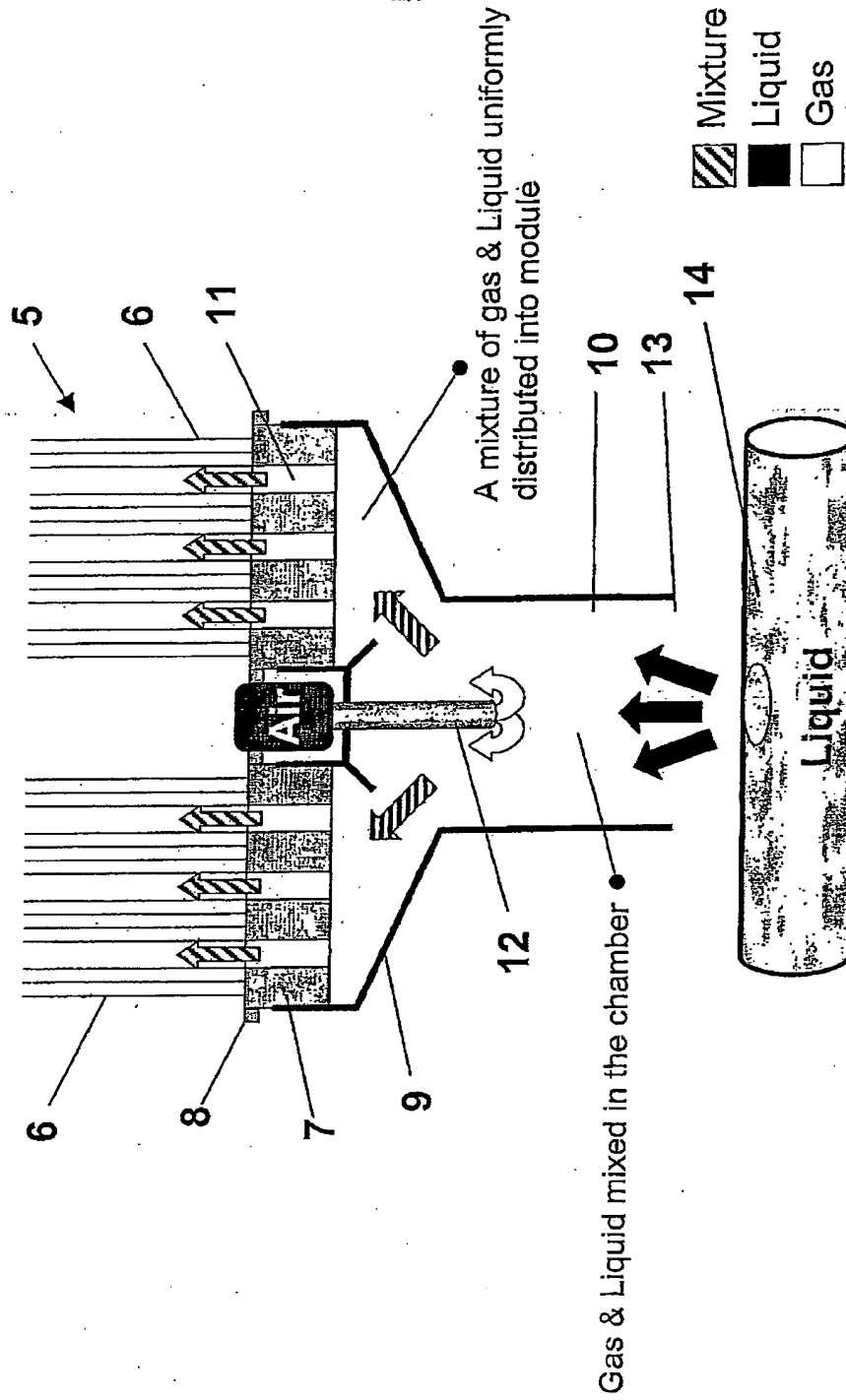

Figure 2.

10/537760

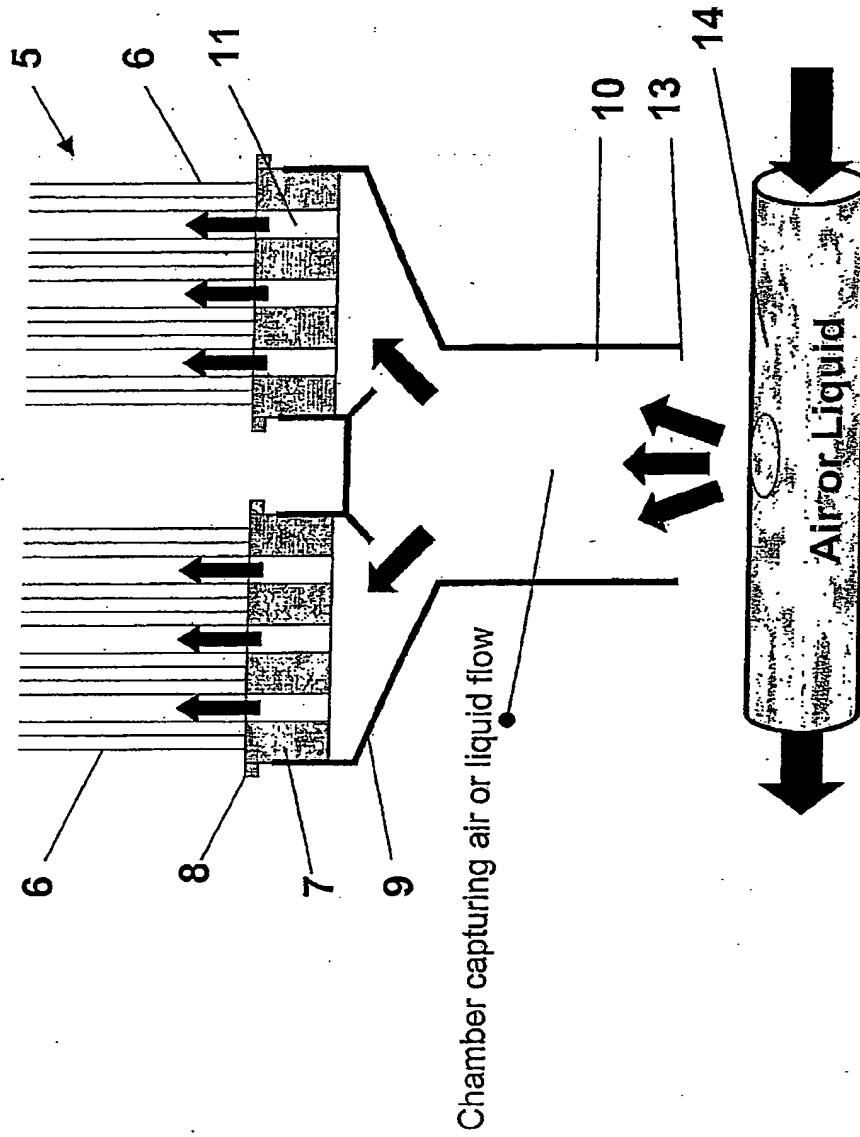

Figure 3.

10/537760

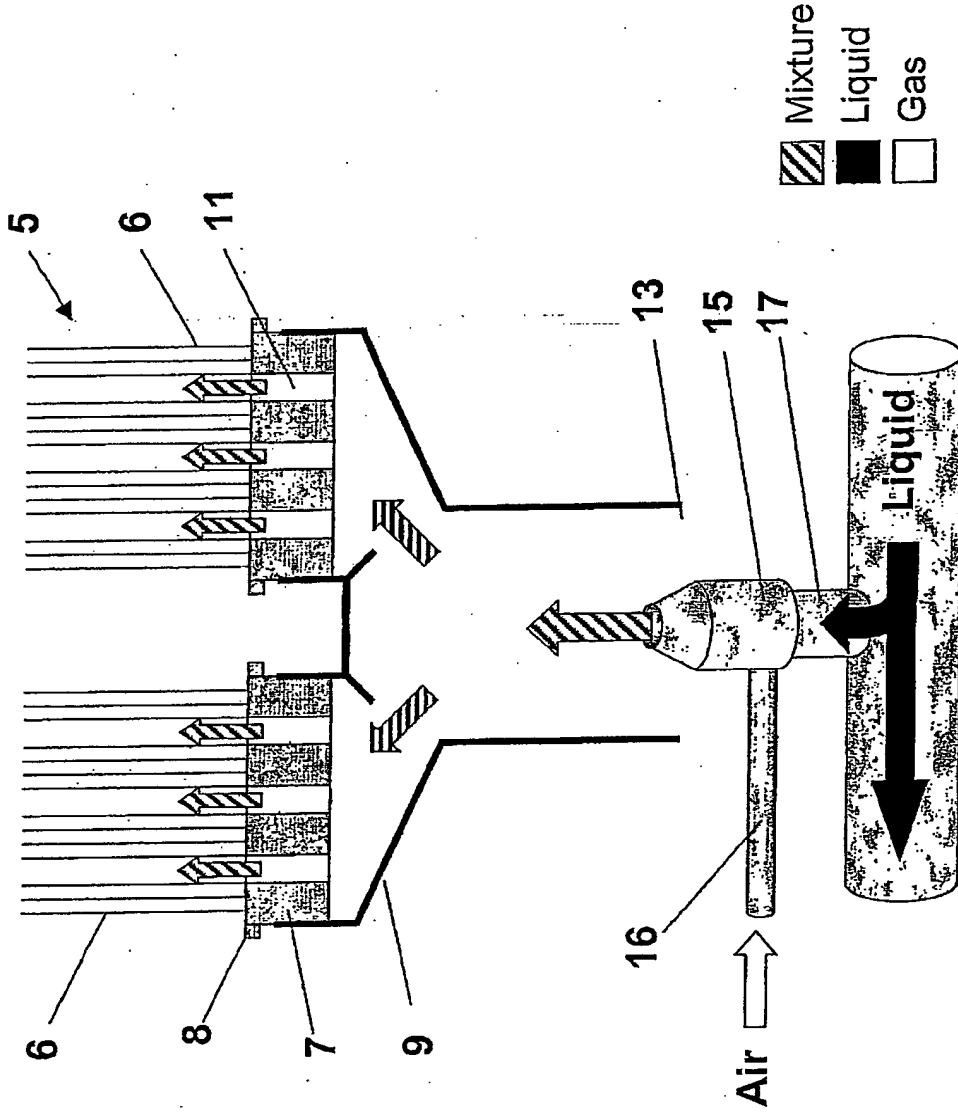

Figure 4.

101537760

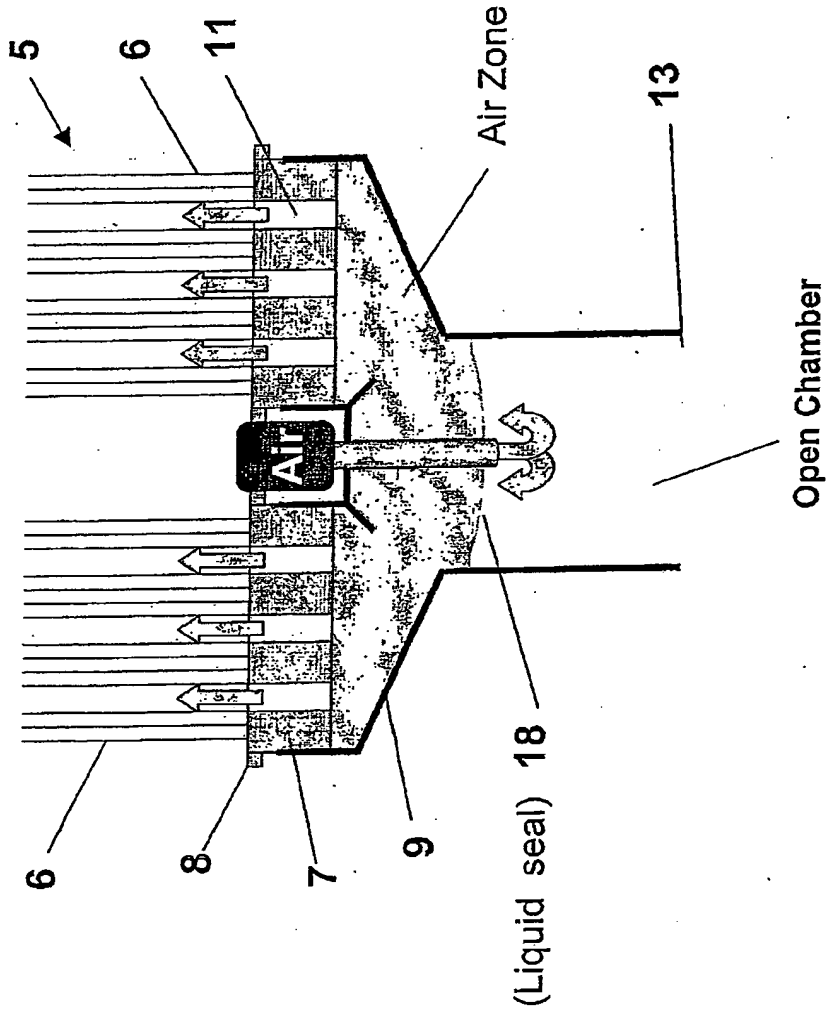

Figure 5.

10/537760

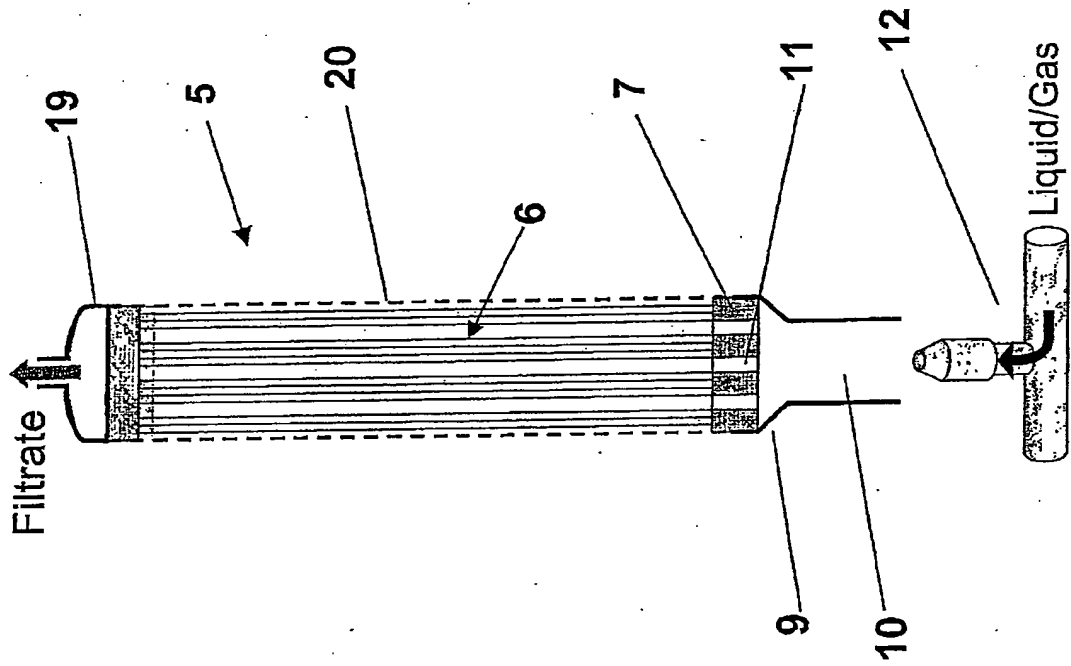

Figure 6. Mixing chamber attached to single module

10/537760

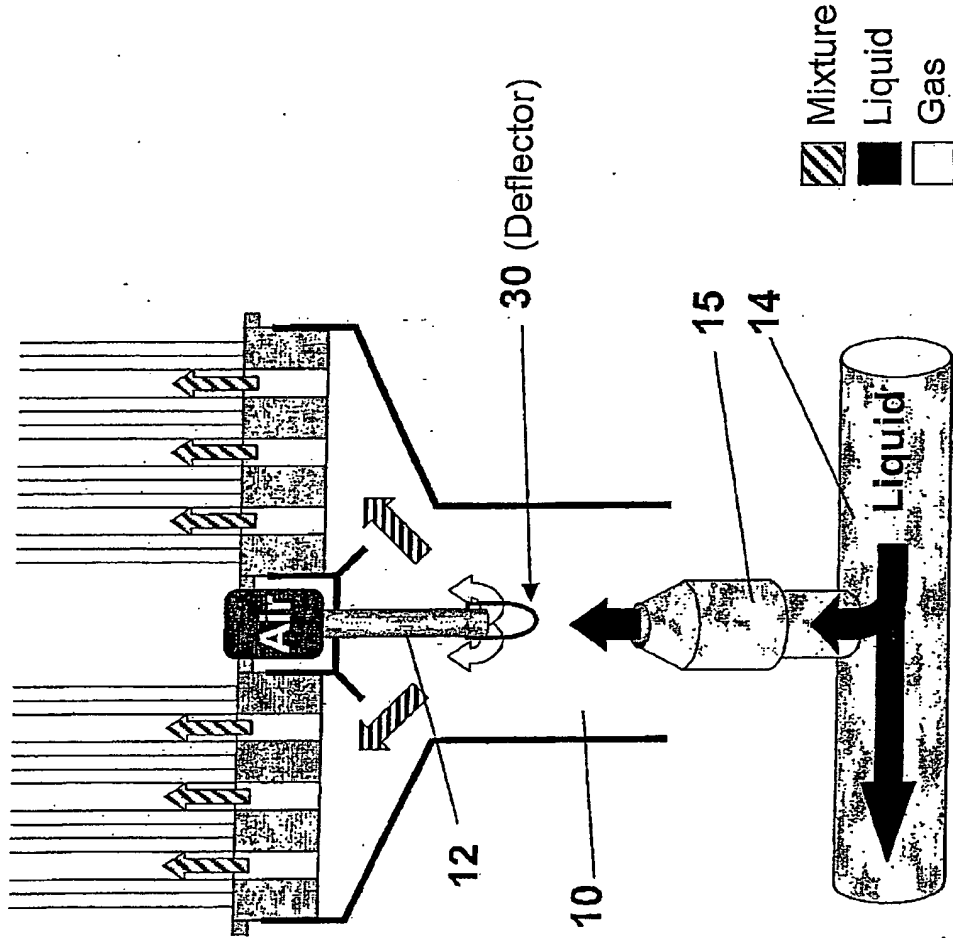

Figure 7.

101537760

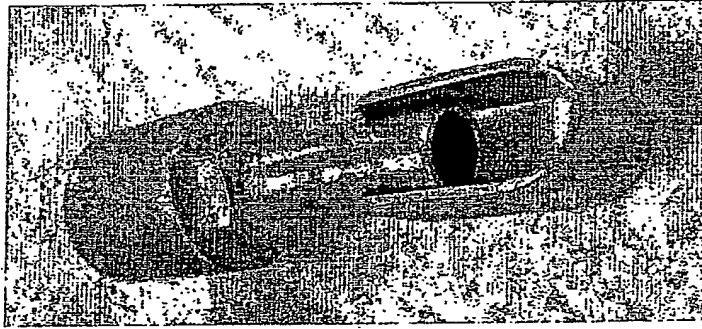

Figure 8b.

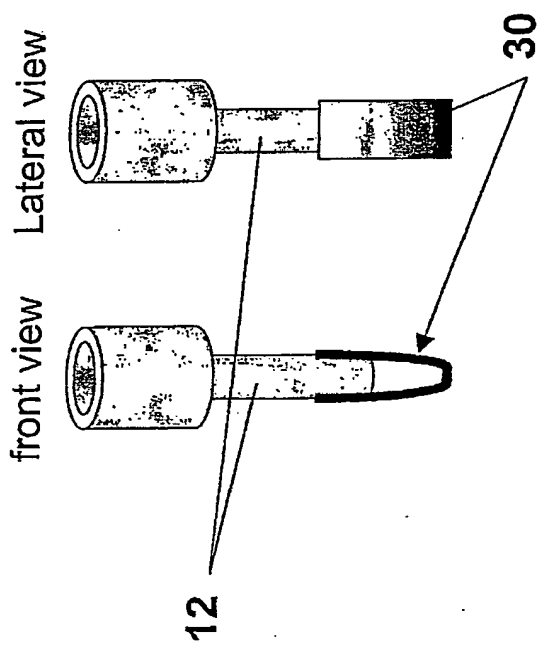

Figure 8a.

10/537760

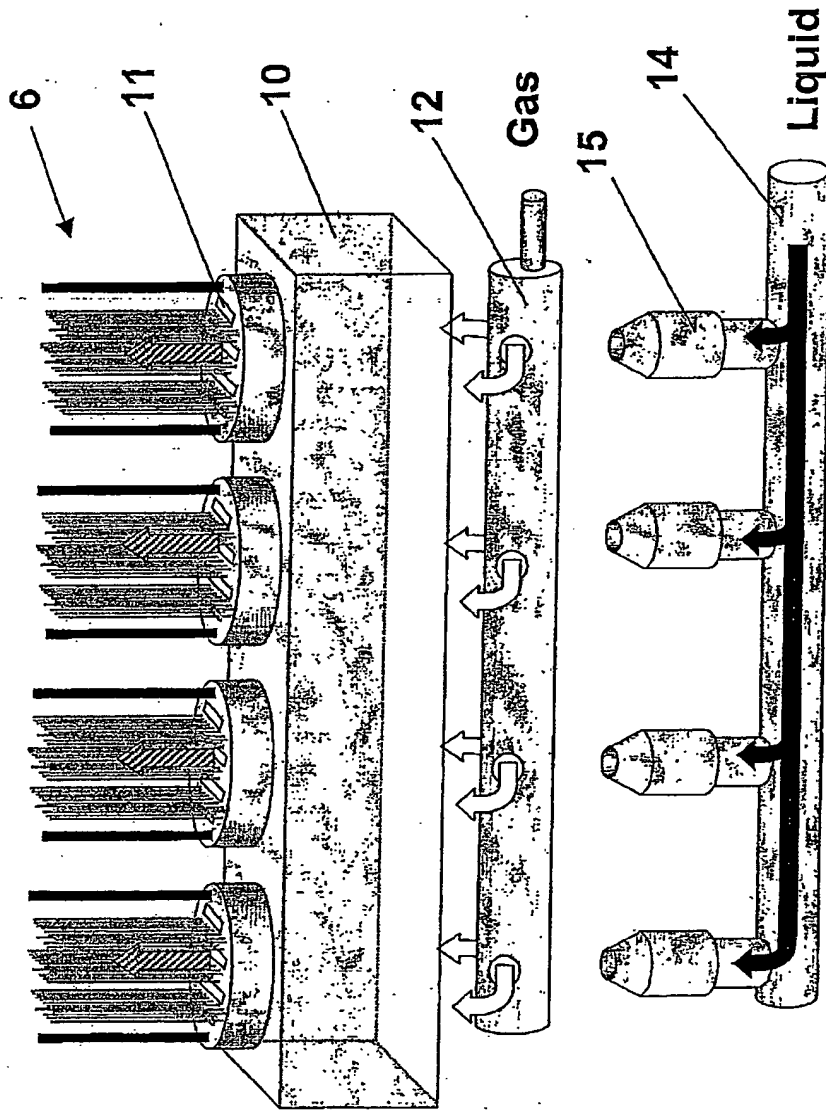

Figure 9.

INTERNATIONAL SEARCH REPORT

International application No.
PCT/AU2003/001632

A. CLASSIFICATION OF SUBJECT MATTER		
Int. Cl. ⁷ : B01D 65/08, B01D 65/02		
According to International Patent Classification (IPC) or to both national classification and IPC		
B. FIELDS SEARCHED		
Minimum documentation searched (classification system followed by classification symbols) B01D 65/08, 65/02		
Documentation searched other than minimum documentation to the extent that such documents are included in the fields searched		
Electronic data base consulted during the international search (name of data base and, where practicable, search terms used) DWPI + KW(CHAMBER+ AND (BUBBL+ OR GAS+))		
C. DOCUMENTS CONSIDERED TO BE RELEVANT		
Category*	Citation of document, with indication, where appropriate, of the relevant passages	Relevant to claim No.
X	WO,A,200018498 (USF FILTRATION AND SEPARATIONS GROUP INC.) 6 April 2000 See whole document	6,17, (23-25), (28-53)
X	WO,A,199828066 (MEMTEC AMERICA CORPORATION) 2 July 1998 See whole document	6,17, (23-25), (28-53)
X	US,A,5639373 (MAILVAGAMAN ET AL) 17 June 1997 See whole document	6,17, (23-25), (28-53)
<input checked="" type="checkbox"/> Further documents are listed in the continuation of Box C <input checked="" type="checkbox"/> See patent family annex		
* Special categories of cited documents: "A" document defining the general state of the art which is not considered to be of particular relevance "E" earlier application or patent but published on or after the international filing date "L" document which may throw doubts on priority claim(s) or which is cited to establish the publication date of another citation or other special reason (as specified) "O" document referring to an oral disclosure, use, exhibition or other means "P" document published prior to the international filing date but later than the priority date claimed "T" later document published after the international filing date or priority date and not in conflict with the application but cited to understand the principle or theory underlying the invention "X" document of particular relevance; the claimed invention cannot be considered novel or cannot be considered to involve an inventive step when the document is taken alone "Y" document of particular relevance; the claimed invention cannot be considered to involve an inventive step when the document is combined with one or more other such documents, such combination being obvious to a person skilled in the art "&" document member of the same patent family		
Date of the actual completion of the international search 22 January 2004		Date of mailing of the international search report 30 JAN 2004
Name and mailing address of the ISA/AU AUSTRALIAN PATENT OFFICE PO BOX 200, WODEN ACT 2606, AUSTRALIA E-mail address: pct@ipaaustralia.gov.au Facsimile No. (02) 6283 3929		Authorized officer MR. OLLEY Telephone No : (02) 6283 2143

INTERNATIONAL SEARCH REPORT

International application No.

PCT/AU2003/001632

C (Continuation). DOCUMENTS CONSIDERED TO BE RELEVANT		
Category*	Citation of document, with indication, where appropriate, of the relevant passages	Relevant to claim No.
A	Derwent Abstract Accession No. 95-077293/11, Class D15, J01 JP07000770 (TOSHIBA KK) 6 January 1995	
A	Derwent Abstract Accession No. 97-232466/21, Class J01, K07 JP09072993 (ORGANO CORP) 18 March 1997	

INTERNATIONAL SEARCH REPORT

International application No.

Information on patent family members

PCT/AU2003/001632

This Annex lists the known "A" publication level patent family members relating to the patent documents cited in the above-mentioned international search report. The Australian Patent Office is in no way liable for these particulars which are merely given for the purpose of information.

Patent Document Cited in Search Report	Patent Family Member			
WO 0018498	AU 61834/99	CA 2342346	EP 1115474	
	NZ 510394	US 2001047962	US 2003075504	
	US 2003205519			
WO 9828066	AU 53957/98	CN 1244814	EP 0952885	
	NZ 336455	NZ 510245	US 6555005	
	US 2002195390	US 2003178365		
US 5639373	AU 14308/99	AU 66528/96	CA 2227692	
	EG 21552	EP 0846023	EP 1053054	
	EP 1170052	EP 1213048	EP 1252921	
	EP 1369165	US 5783083	US 5910250	
	US 5944997	US 6042677	US 6193890	
	US 6294039	US 2002153299	US 2003136746	
	US 2003141248	US 2003164332	WO 9706880	
	WO 9929401			
				END OF ANNEX

**This Page is Inserted by IFW Indexing and Scanning
Operations and is not part of the Official Record**

BEST AVAILABLE IMAGES

Defective images within this document are accurate representations of the original documents submitted by the applicant.

Defects in the images include but are not limited to the items checked:

- BLACK BORDERS
- IMAGE CUT OFF AT TOP, BOTTOM OR SIDES
- FADED TEXT OR DRAWING
- BLURRED OR ILLEGIBLE TEXT OR DRAWING
- SKEWED/SLANTED IMAGES
- COLOR OR BLACK AND WHITE PHOTOGRAPHS
- GRAY SCALE DOCUMENTS
- LINES OR MARKS ON ORIGINAL DOCUMENT
- REFERENCE(S) OR EXHIBIT(S) SUBMITTED ARE POOR QUALITY
- OTHER: _____

IMAGES ARE BEST AVAILABLE COPY.

As rescanning these documents will not correct the image problems checked, please do not report these problems to the IFW Image Problem Mailbox.